

Buggy Accessories

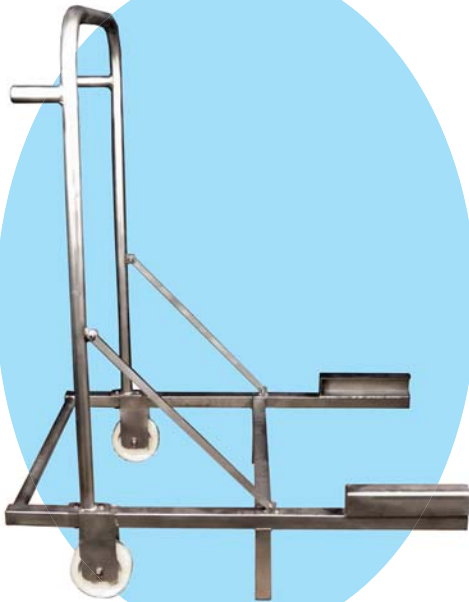

Wash Stand - BG101007

APPLICATION:

Designed for use in the food processing industry to aid in cleaning our Dump Buggies. Our single person Dump Buggy Wash Stand is ready to help when it is time to wash the buggies. This Wash Stand allows buggy to be raised using the lifting lugs, then tilted to the horizontal position. Allowing it to be washed clean and rinsed inside and out. It lifts the buggy approximately 28" above the floor while reducing back strain and injury.

MATERIAL CONSTRUCTION:

Our Dump Buggy Wash Stand frame is constructed from heavy gauge square and round tube T-304 Stainless Steel. It is rust proof and corrosion resistant and is designed to provide a long service life. The Wash Stand ships Knocked Down to save on freight and is easily assembled.

APPLICATION:

We've designed this loose fitting Lid with handle to aid as a cover that can be used with any of our dump buggies. It has 1.5" turned down edges. This lid is rustproof and corrosion resistant.

MATERIAL CONSTRUCTION:

Constructed from heavy-duty T-304 Stainless Steel 16 gauge material. Unit is fully welded and easy to clean. Ships assembled - ready to use.

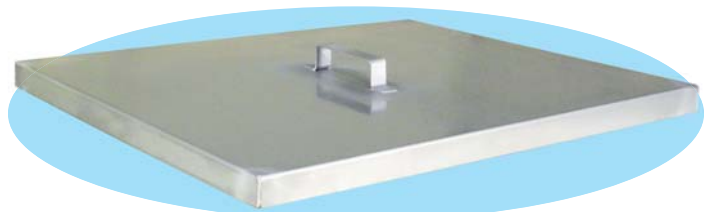

Stainless Steel Buggy Lid - BG201025

Manufactured by:

DC TECH INC.

619 E 19th Street
Kansas City, MO 64108-1743

Toll Free: 877-742-9090
Fax: 816-842-4121
www.dctech-inc.com
sales@dctech-inc.com

Note: You may print this with your company name and address as "Distributed By:" in place of our information above. See the PDF logo at the bottom of each page on our website.

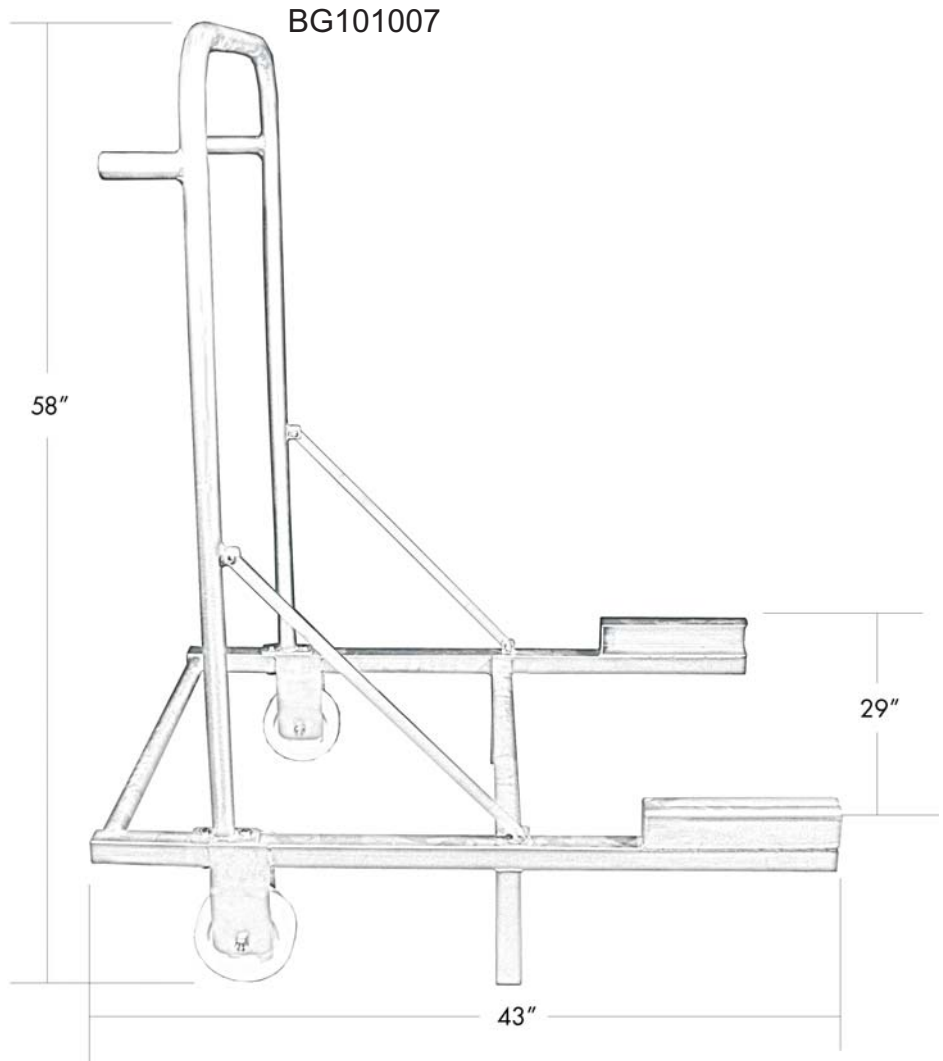

BG201025



Item # _____

Qty: _____

Job: _____

Model #	Description	Height	Width	Length
BG 101007	Buggy Wash Stand	58"	29"	43"
BG201025	Loose Fitting SS Lid	3"	26"	28.5"

Manufactured by:

DC TECH INC.

619 E 19th Street
Kansas City, MO 64108-1743

Toll Free: 877-742-9090

Fax: 816-842-4121

www.dctech-inc.com

sales@dctech-inc.com