

Lander/Spreader/Tree



APPLICATION:

Our Single Rail Beef Lander is used by the food processing industry as a carcass dressing landing rail. The Trolley landing system consists of this track section and the Beef Spreader (sold separately) shown below.

MATERIAL CONSTRUCTION:

The Lander assembly is a 6 foot track section - 1/2" x 2-1/2" track. Our lander is constructed from heavy gauge steel and is continuously welded for added strength. Landers have a painted finish.

Options: Available in a 10" Hanger or a 12" Hanger.



Single Rail Beef Lander - LR111001

APPLICATION:

The 48" Beef Spreader has two hooks that engage the top frame of trolleys to raise spreader above track..

MATERIAL CONSTRUCTION:

Our Spreader is constructed of solid steel round and flat bar, and is also continuously welded for added strength. Precision cut solid steel plate hooks come standard on Spreaders. Spreaders have a painted finish.

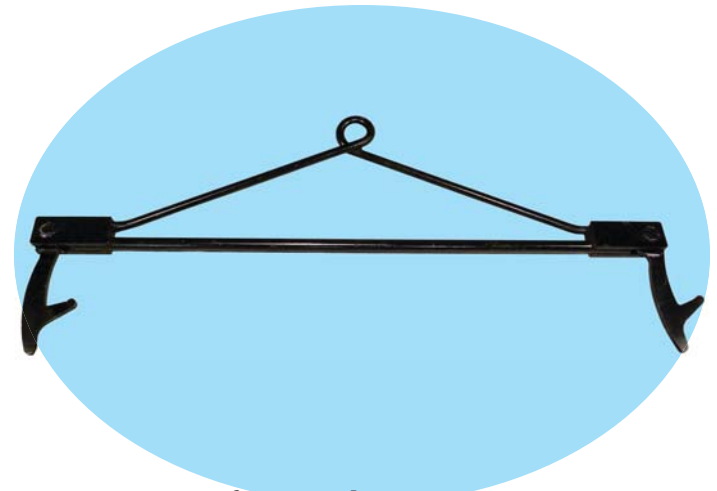

Beef Spreader - SD111001

APPLICATION:

Our heavy duty, fully welded steel Frame Beef Tree features a 48" spread between hooks and a black enamel finish. .

MATERIAL CONSTRUCTION:

Features heavy steel rod construction with a 13" vertical height above hooks. It is supplied with two 9" Stainless Steel Hooks.

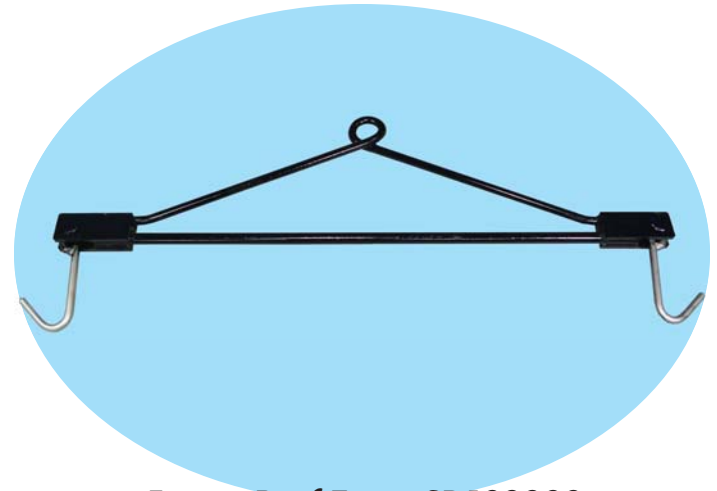

Frame Beef Tree - SD103000

Distributed by:

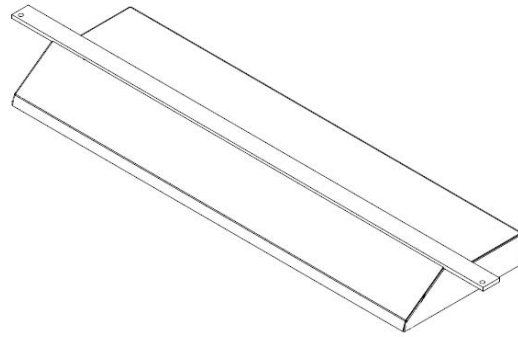
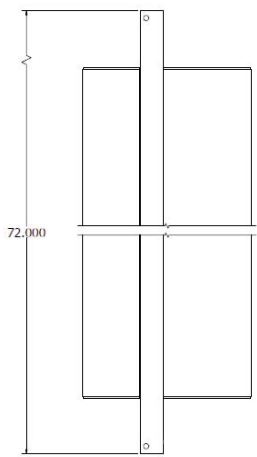

LR111001

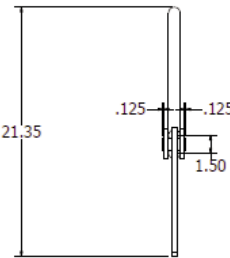
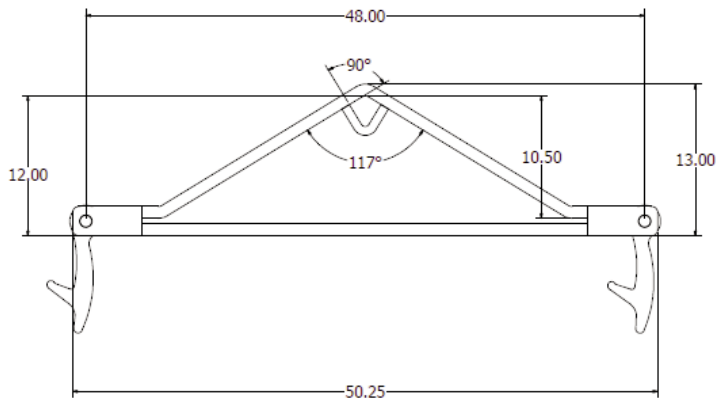
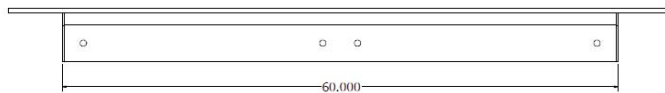
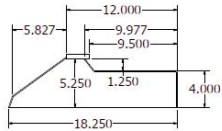

SD111001

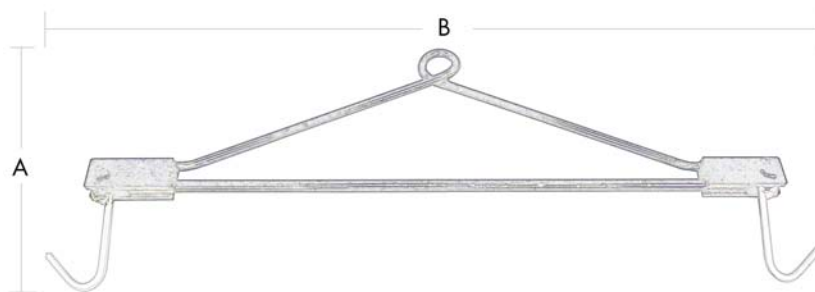
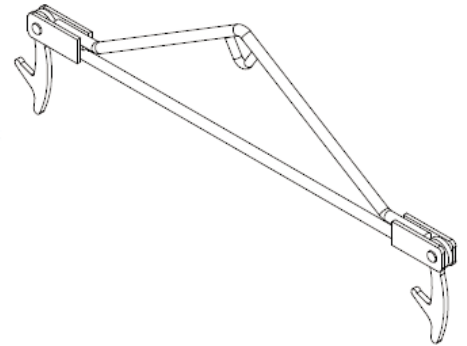

SD103000

Model #	Description	"A" Height	"B" length	Depth
LR 111001	10" Steel Lander	16"	72"	6"
LR 111002	12" Steel Lander	18"	72"	6"
SD 111001	Painted Beef Spreader	21.35"	48" Between Hooks	
SD 103000	Frame Beef Tree	21.35"	48" Between Hooks	

Item # _____

Qty: _____

Job: _____

Manufactured by:

DC TECH INC.

619 E 19th Street
Kansas City, MO 64108-1743

Toll Free: 877-742-9090

Fax: 816-842-4121

www.dctech-inc.com

sales@dctech-inc.com

© 2016 DC TECH INC. - ALL RIGHTS RESERVED • DC Tech Inc., reserves the right to modify or make changes at any time without notice.