

500-lb Trucks



500 # Raised - TKS05003

MATERIAL HANDLING APPLICATION:

Our Stainless Steel trucks are designed to be used in food processing plants. The 500-lb capacity (7.6 cu. ft.) trucks are available in two styles, Elevated and Standard.

AVAILABLE OPTIONS:

» Drain and Cap



500 # Standard - TKS05002

MATERIAL CONSTRUCTION:

These 500-LB capacity trucks are made of heavy-duty 14 gauge T-304 Stainless Steel and are continuously welded for strength and sanitation. Solid rod reinforcement in the top ends and corners adds strength and helps prevent damage. Interior welds are Tig welded and glass bead blasted smooth. The exterior is Mig welded for added strength and glass bead blasted also. All sanitary corners have a 1" radius for easy cleaning. The TKS05002 and the TKS05001 Standard Trucks, one with drain and one without, feature 6" x 2" wide center pivot wheels, which allow for easy pushing and turning even with heavy loads. The TKS05003 Raised Truck comes complete with two 5" x 2" wide rigid casters with black poly wheels and two 5" x 2" wide swivel casters with black poly wheels.

Distributed by:

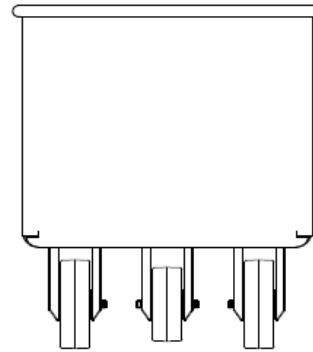
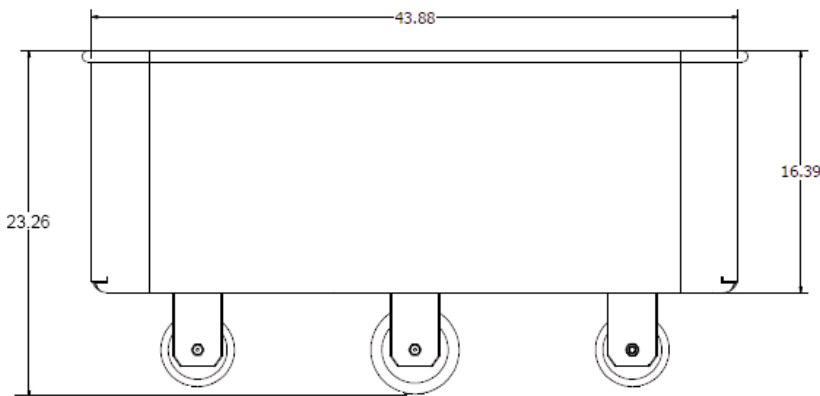
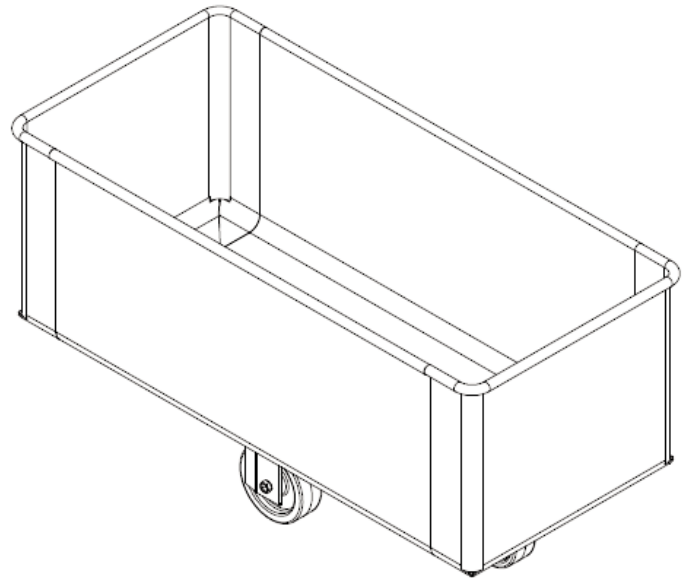
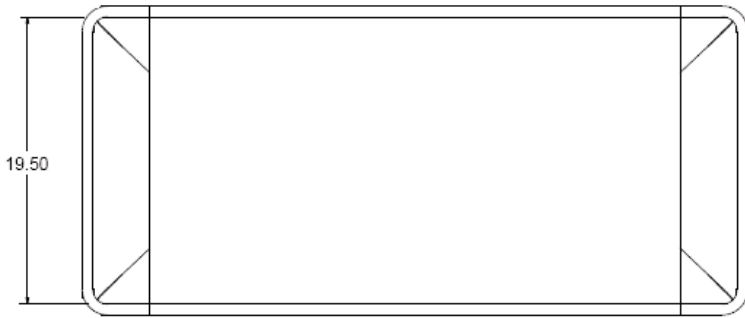

Item # _____

Qty: _____

Job: _____

Model #	Description	"A" Overall Height	"B" Inside Length	"C" Inside Width	"D" Inside Depth
TKS05001	500# Truck w/o Drain	23.26"	43.88"	19.5"	16.39"
TKS05002	500# Truck w/Drain & Cap	23.26"	43.88"	19.5"	16.39"
TKS05003	500# Elevated Truck w/Drain & Cap	32"	43.88"	19.5"	16.39"

Manufactured by:

DC TECH INC.

619 E 19th Street
Kansas City, MO 64108-1743

Toll Free: 877-742-9090
Fax: 816-842-4121
www.dctech-inc.com
sales@dctech-inc.com